



Supplementary
Fitment Guide

NISSAN

Silvia S15

2000

Written By: James

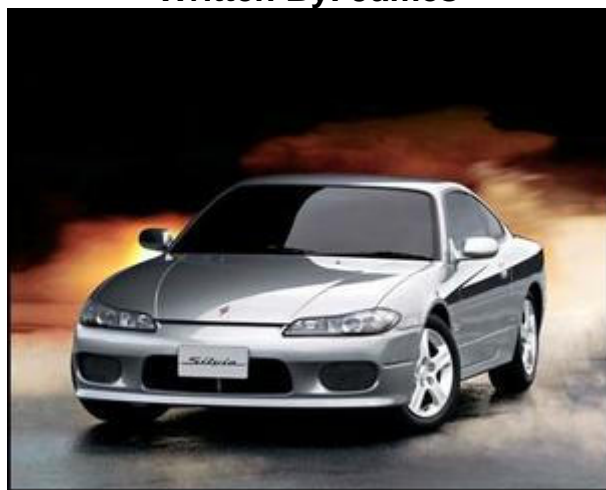

Step 1. Remove the screws from the cluster surround and it should pull out.



Step 2. Remove the 3 Cluster Screws.



Step 3. Pull out the surround with care and Disconnect the 3 plugs, by wedging a flathead in the tab and pulling it out. Now you will see 3 plugs (1 white plug, and 2 brown) the plug you want is the white plug the far left one circled in yellow below.



Step 4. Dress the 3 cables from your shift-i in and around the back of your cluster and prepare to make the connections.



Step 5. Making the Connections

Using the Connectors that came with your shift-i



Make the Following Connections

Shift-i	Instrument Wiring	Purpose
Black/Red	Green/Yellow (Pin 12)	Ignition
Black/blue	Blue/Orange (Pin 15)	RPM Signal/Tacho
Black	Black (Pin 9)	Ground

Below are some Attached diagrams to aid your connections

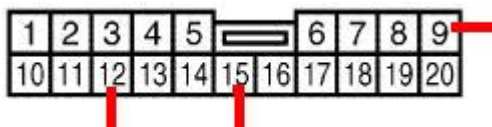

Wiring Diagram — METER —

EL-METE

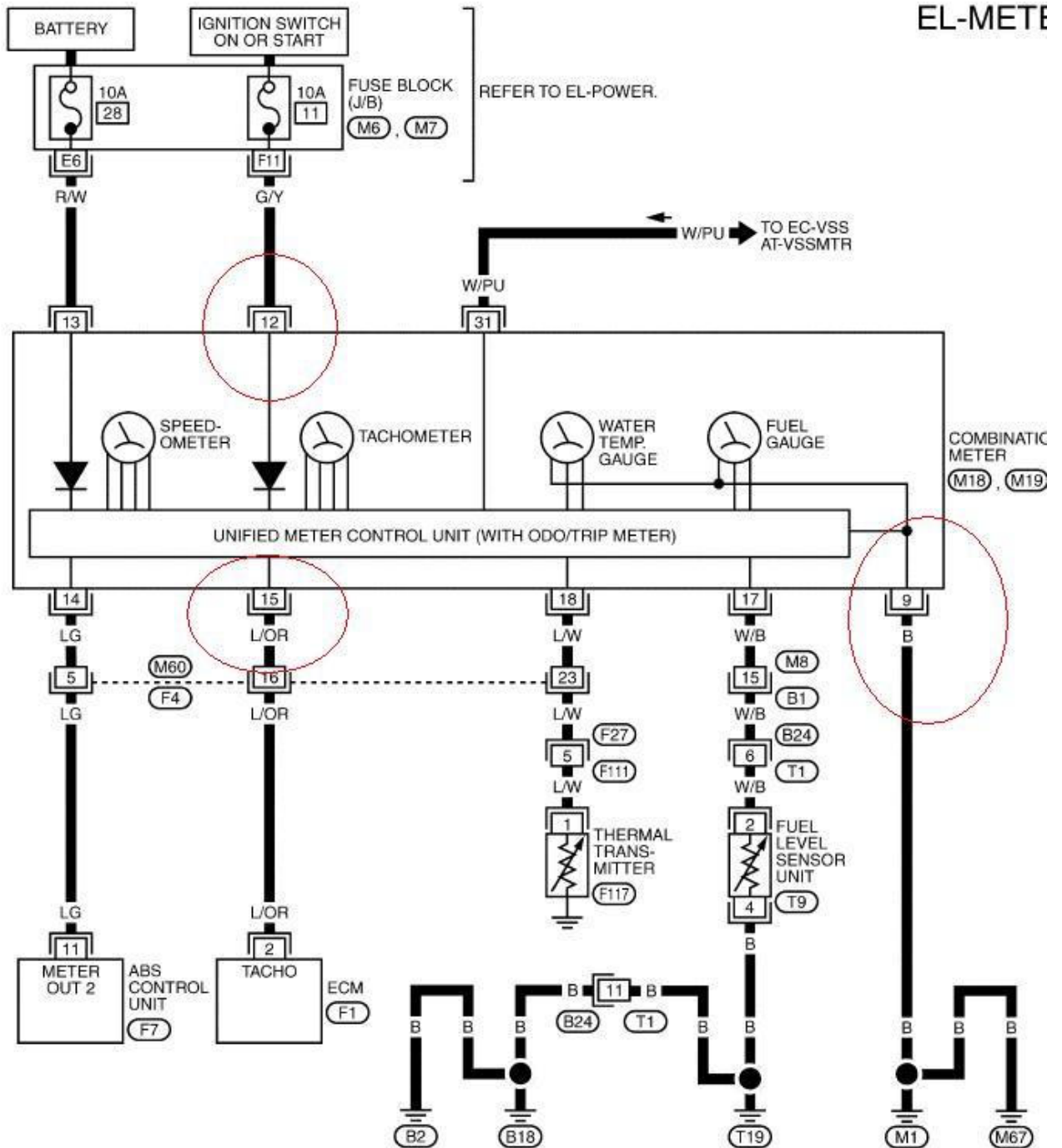

You don't need to adjust the "Calibration", as the default setting of 2 works.

I just went straight to setting the low point at 4000 and high point at 7000 and its pretty much spot on.

Install Complete and enjoy!

Handy Tips, that i wish someone told me

1. Prepare yourself with a Philips and Flat head screwdriver, some tape and a pair of pliers
2. Be careful when removing the Cluster, it is very easy to Scratch the plastic
3. Double check all connections are correct before putting everything back together. It is safe to turn on the car without the Cluster plugged in, as i found out.
4. Read through the manual and check how the shift-i should be functioning if connections are made correct.

