



Supplementary Fitment Guide

Honda Civic EP3 Type R 2001..2005

Author

Philip Lee

"Disclaimer: This information is provided as a GUIDE ONLY. Neither the author nor Ecliptech Innovations take any responsibility for the outcomes of anyone who rely on any material/information within this guide. You follow these steps at your own risk! If in doubt, please refer to the manual or contact us."

V1.0

Ecliptech Innovations Pty. Ltd.

1. Remove the plastic trim around the dash:

- lower your steering wheel to the lowest position;
- use your fingers to pull the trim gently towards you;
- there are 4 clips (B & D) and 4 tabs (C & E);
- no tool is required and be careful not to damage the plastic, clips and tabs.

Fastener Locations

B ▷ : Clip, 2

D ▷ : Clip, 2

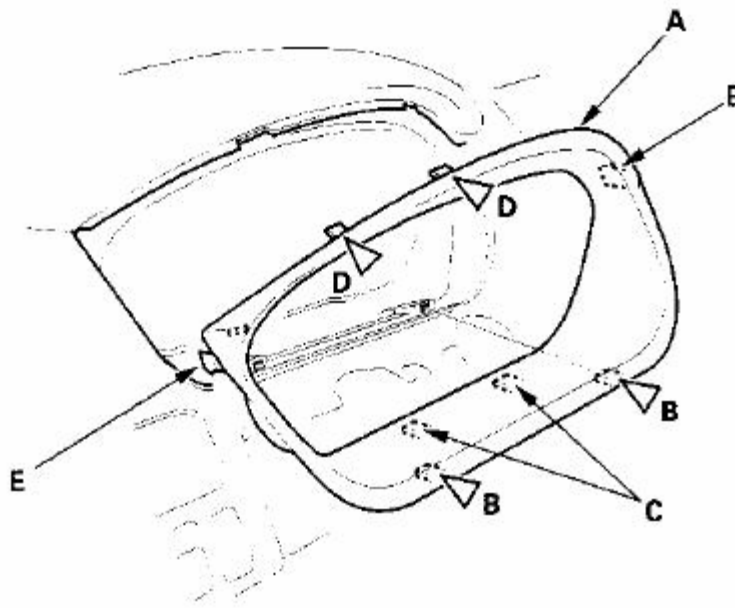

2. Remove the dial cluster:

- undo the 3 screws outlined by the red circles on the below diagram;
- undo the 2 plugs (blue and green) from the top and remove the cluster;
- be careful not to scratch the surrounding plastic and the steering wheel;

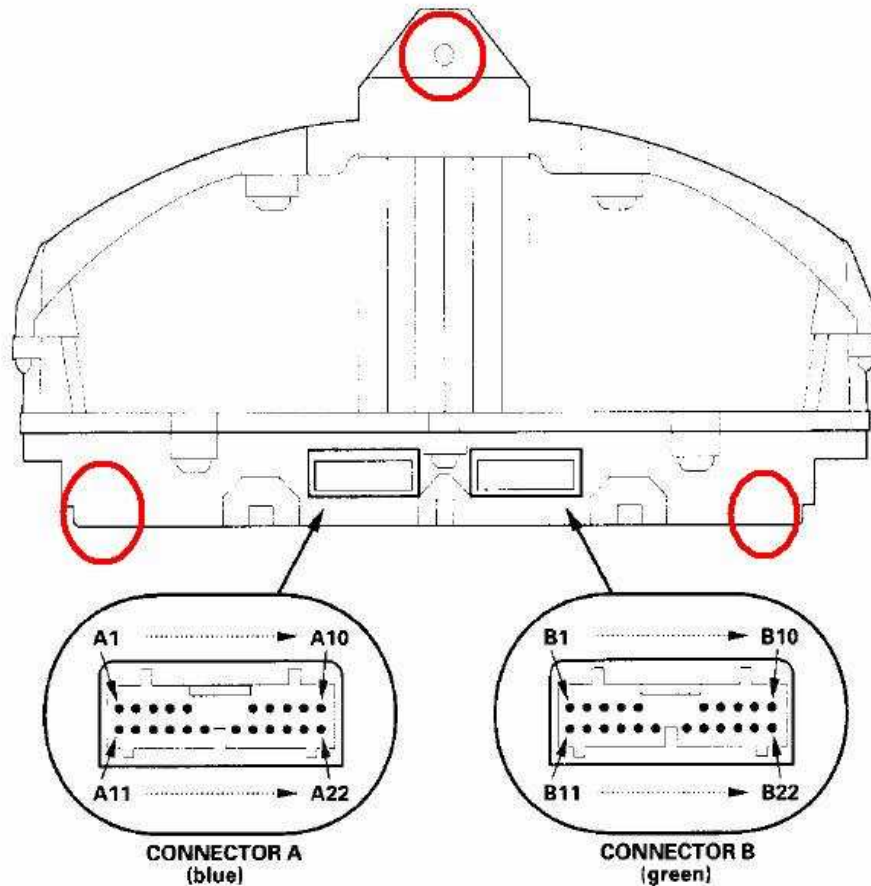

3. Wires:

All required wires are on the green plug. The above diagram should be viewed from the wires end.

Connect the Shift-I wires to the following wires on the green plug:

Shift I	Harness (Green)
Ground	Black B12 (Black)
Ignition.....	Black/Red B2 (Yellow)
Tacho.....	Black/Blue B4 (Blue)

NB: B11 is also ground but it's connected to something else so I preferred to use B12 instead. B1 is constant power and Shift-I will not turn off with ignition is off if this wire is used instead of B2.